



Suitable for notebooks up to 15.6"

### All-purpose notebook mobile cart Atdec A-NC

The Atdec A-NC all-purpose mobile notebook cart incorporates a range of clever features to enhance the use of notebook computers (up to 15.6") in a range of working environments. Ergonomic, hands free and gas strut assisted height adjustment is incorporated to provide support for sit stand environments while the lockable work surface enhances security. The work surface also offers protection for notebooks in dirty environments by concealing components and encouraging the use of an external keyboard and mouse (via retractable keyboard and mouse tray). It incorporates high quality, soft edged and lockable castors for added stability and a push pull handle for easy cart mobility. Cable management is handled internally and includes a power supply and cable storage area at the rear of the cart.



### Product key features:

- Supports notebooks up to 15.6"
- Ideal for medical environments
- Durable Steel, Aluminium and MDF construction
- Offers protection for notebooks in dirty environments



Internal cable management with power supply and cable storage at rear

325mm of height adjustment

Ergonomic gas strut assisted height adjustment for sit/stand applications

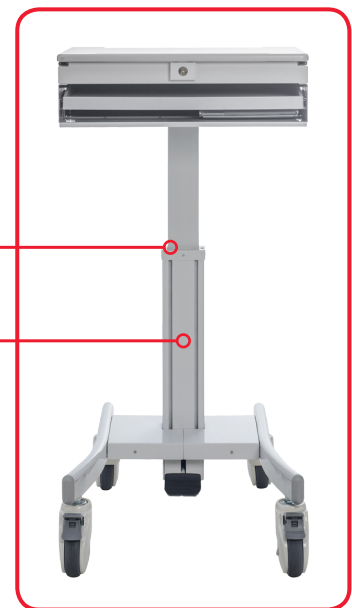

High quality, soft edged and lockable castors for stability and floor protection



Lockable work surface for notebook security



Atdec Global [www.atdec.com.au](http://www.atdec.com.au)  
Atdec North America [www.atdec.com](http://www.atdec.com)

## Product information

Product Code	Load capacity	Material	Colour
A-NC	5kg (11lbs)	Steel, Aluminium and MDF	White

## Package information, single unit

Size	Ship weight	UPC code	Contents
61cm x 45cm x 67cm (24" x 17.7" x 26.4")	42kg (92.4lbs)	881493009356	All hardware required for installation supplied

No master pack available, ships as single unit only

## Technical drawings

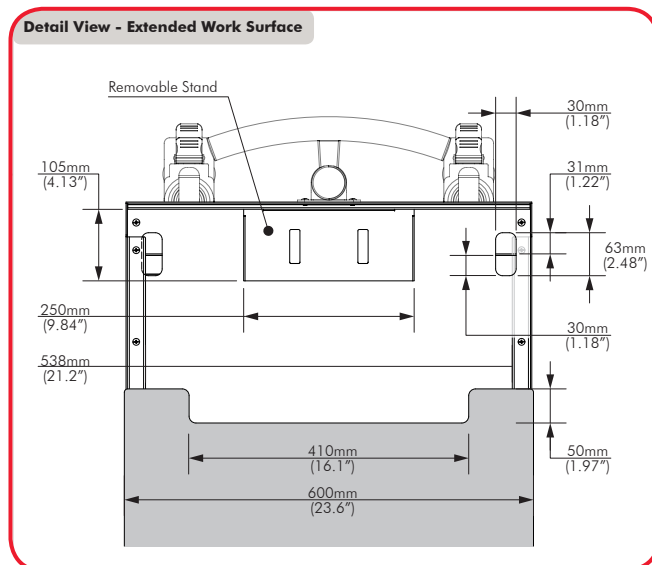
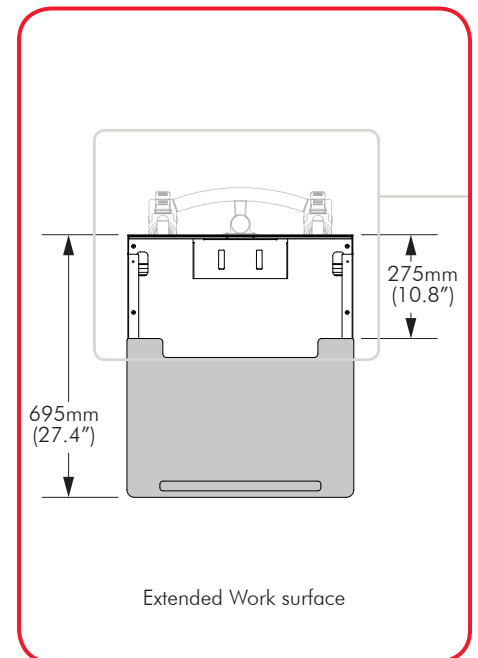
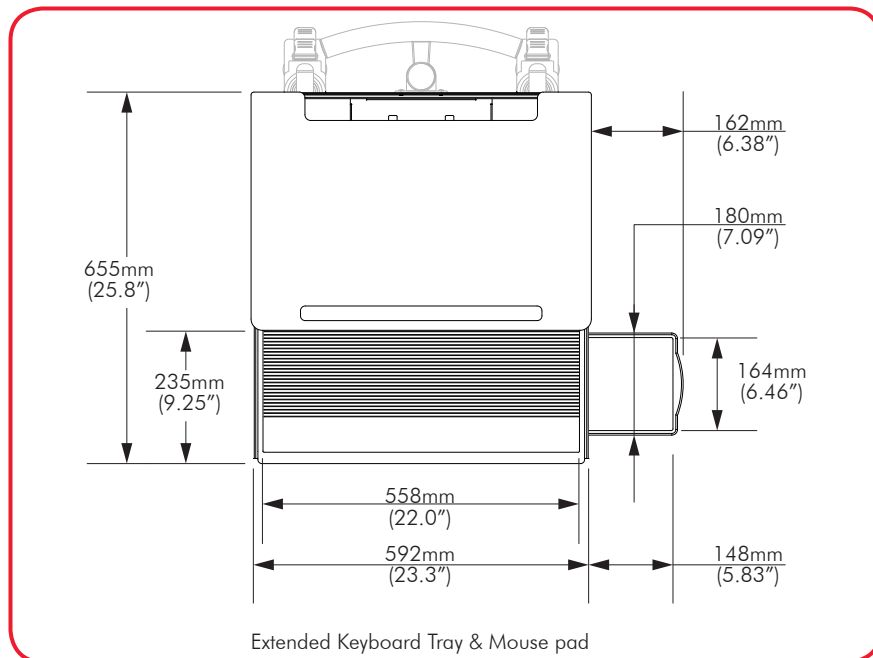

Atdec mounts are designed, developed and tested in Australia. While all efforts have been made to ensure the information in this brochure was correct as of the date of printing, we reserve the right to change specifications without notice. Please refer to the website for our full range along with the latest details on specifications, compatibility and dealer location. Atdec is a registered trademark with all rights reserved. Copyright November 2014.



Atdec Global [www.atdec.com.au](http://www.atdec.com.au)  
Atdec North America [www.atdec.com](http://www.atdec.com)