

General Features

Maximum Weight:

25kg (55lbs)

Tilt Adjustment:

ARM $\pm 5^\circ$ MOUNT $\pm 20^\circ$

Roll Adjustment:

MOUNT $\pm 5^\circ$

Color:

Silver

Warranty:

10 years

Dimensions

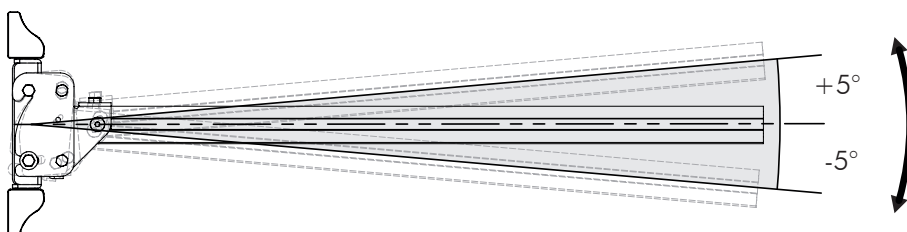
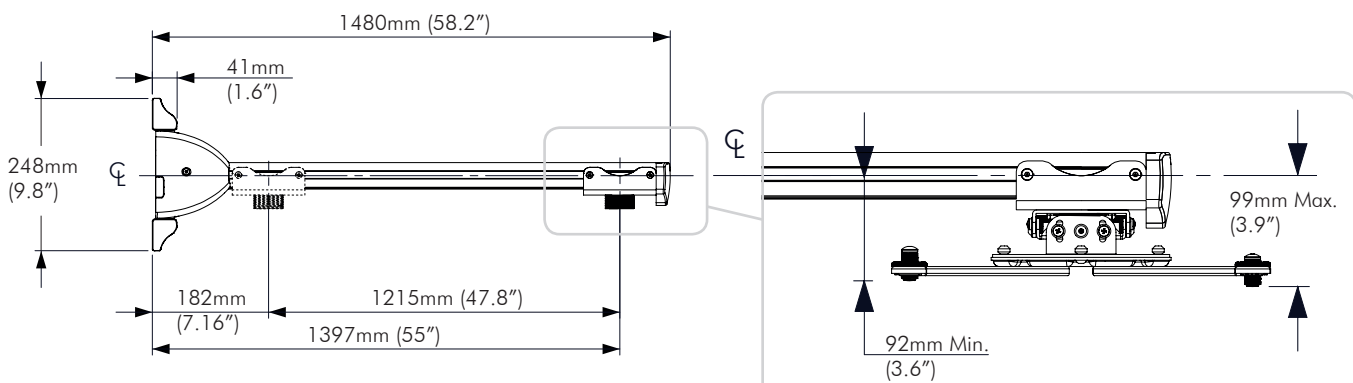
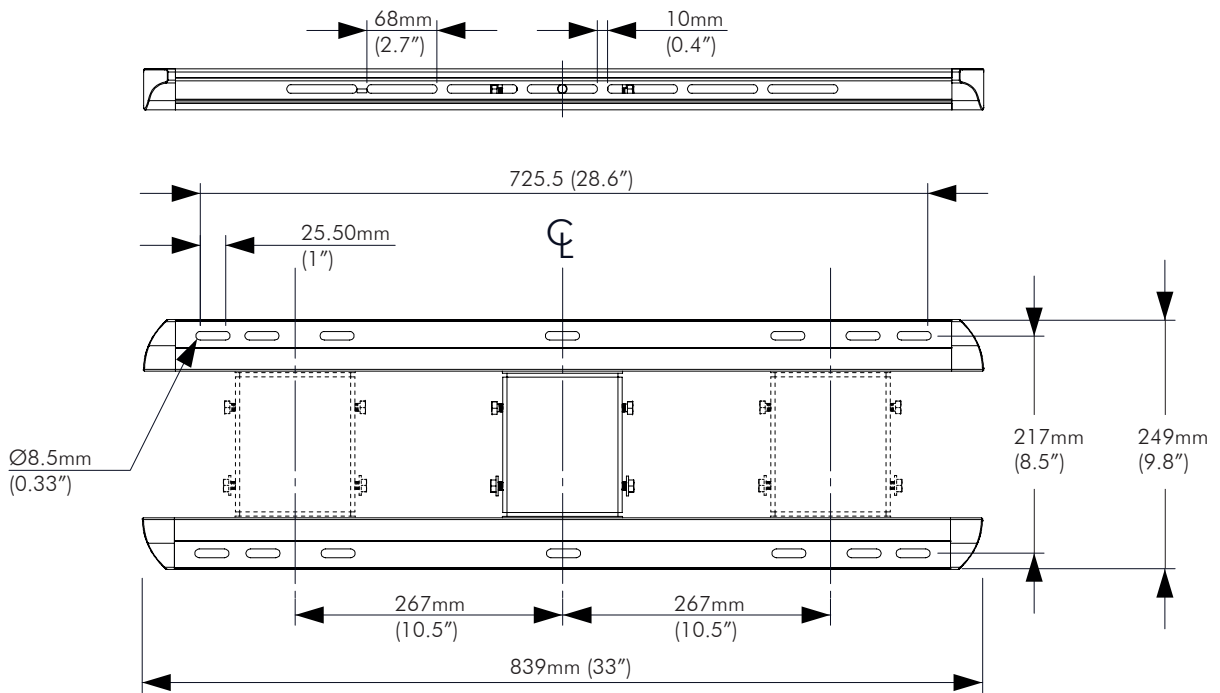

The Support Arm can be adjusted by $\pm 5^\circ$ to account for wall slope or individual projector characteristics.

Dimensions

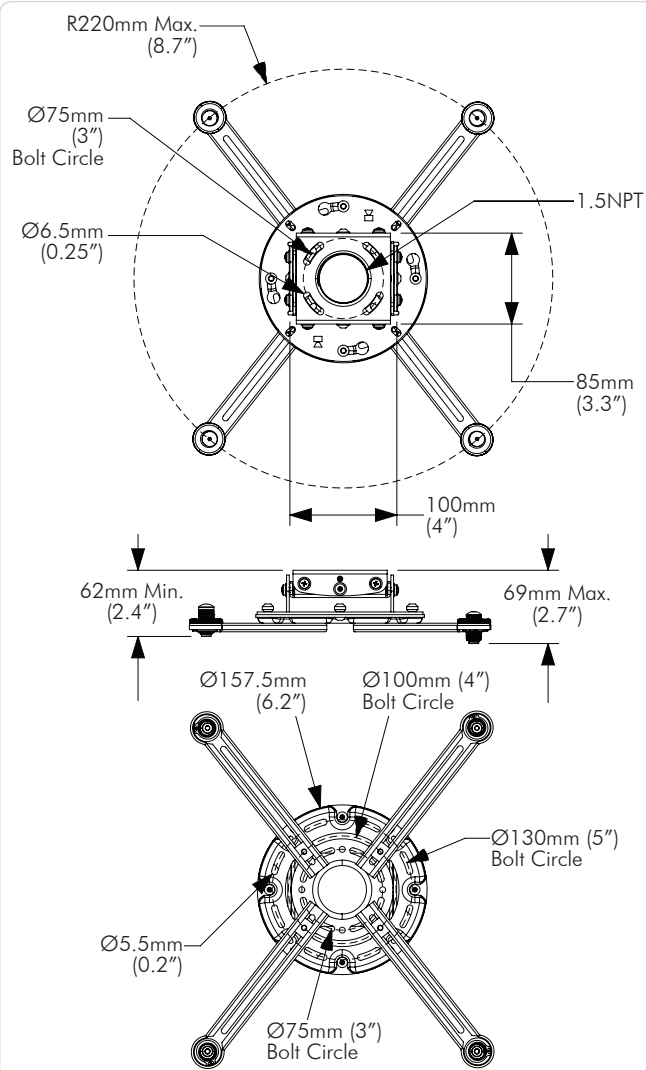

Roll Adjustment:

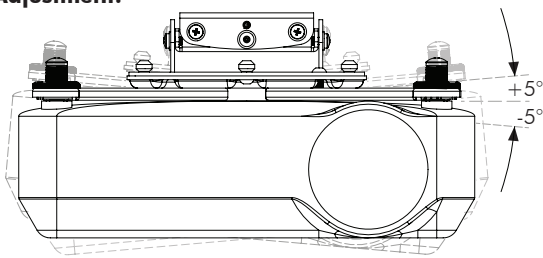

FRONT VIEW

4-LEG MINIMUM DISTANCE:

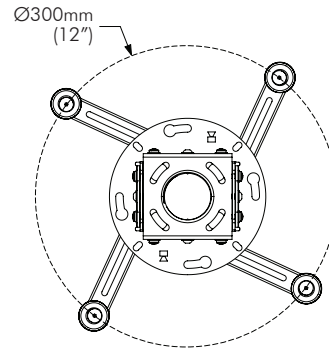

3-LEG MINIMUM DISTANCE:

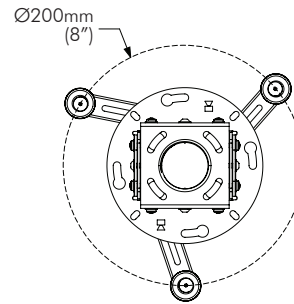

Tilt Adjustment:

Note: Depending on where the projector is mounted along the support arm and if the projector extends from the centre of the mount more than 8"/200mm, the tilt adjustment achievable on the mount may be reduced.

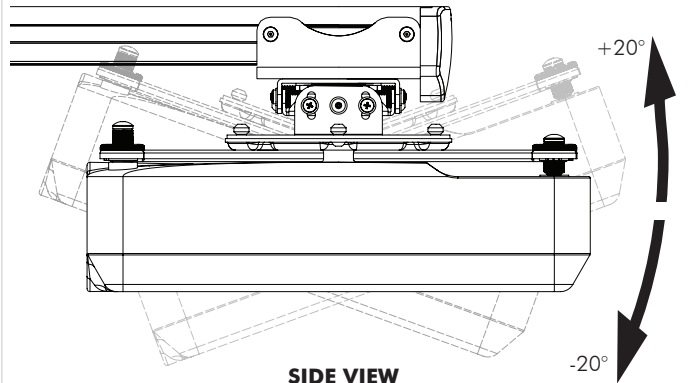

SIDE VIEW