

Focus | Dual desk monitor arm VF-AT-D

For users who require a dual monitor configuration, the Focus VF-AT-D polished aluminium mount can revolutionize any workspace. This desk mount supports two LCD flat screens and frees up valuable desk space for enhanced productivity. Holding the two displays side by side or back to back, viewing comfort and productivity is dramatically increased through easy repositioning of the screens by adjusting your screens in and out for the ideal focal length. Ergonomic by design, tilt, pan, rotation, display height and focal distance are adjustable by the user with ease. Cables are cleverly managed for a clean look and to reduce clutter.

 **Mounting hole pattern:**
75x75mm & 100x100mm mounting
(100x200mm optional)*

 **Maximum weight carrying capacity:**
8kg (17.6lbs) per display



Product key features:

- ✕ Suitable for displays up to 27" in size
- ✕ Improves ergonomics of any work place
- ✕ Bolt through and desk clamp mounting options included
- ✕ Sleek and contemporary design

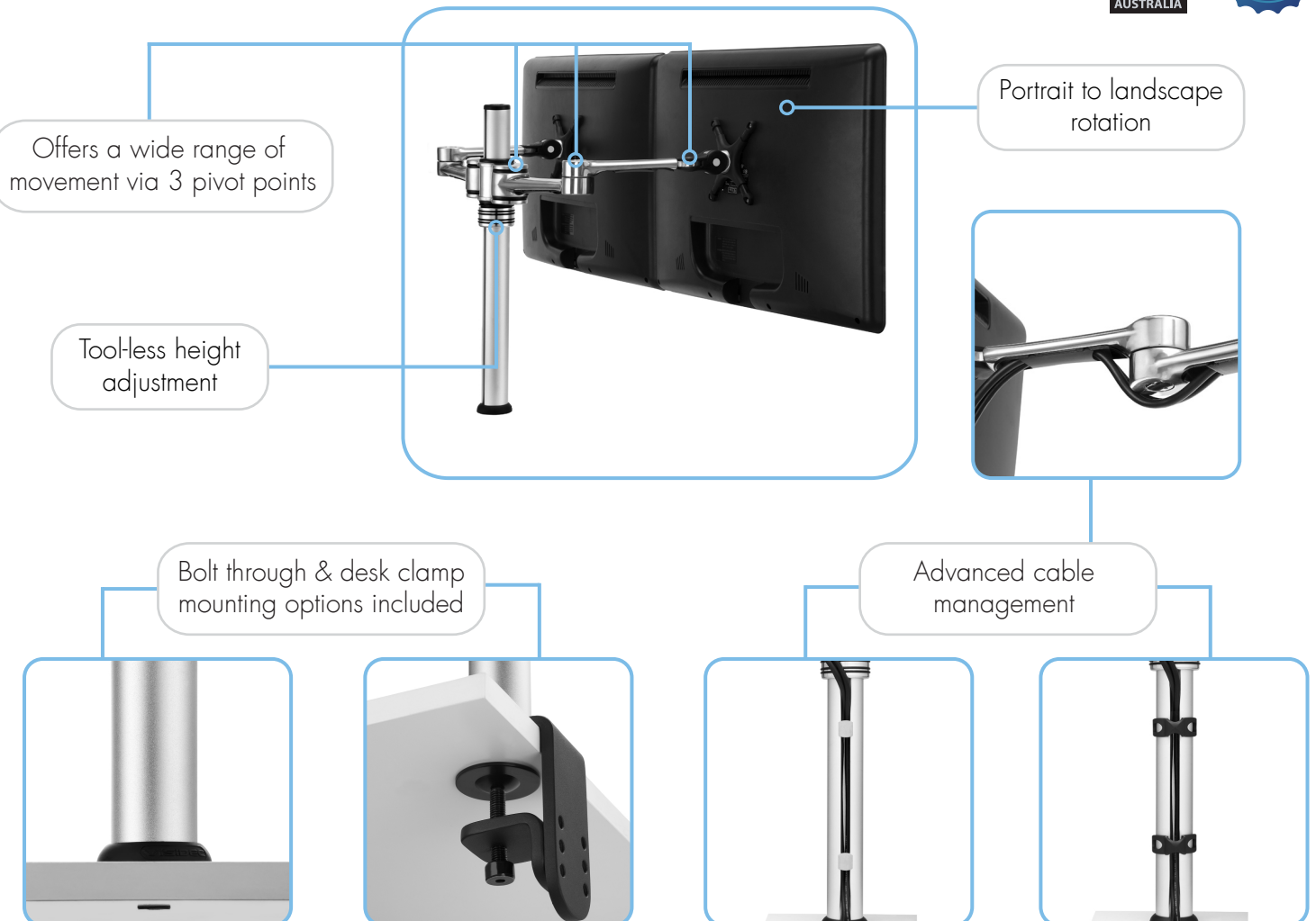

*via additional accessory AC-AP-2010 (sold separately)

Product information

Product Code	Load capacity	Material	Colour
VF-AT-D	8kg (17.6lbs) per arm	Aluminum	Polished Aluminum

Package information, single unit

Size (L x W x H)	Ship weight	UPC code	Contents
56cm x 23cm x 12cm (22.75" x 9" x 5")	3.7kg (8.2lbs)	881493004351	All hardware required for installation supplied

Package information, master pack

Size (L x W x H)	Ship weight	UPC code	Units per master pack
56cm x 47cm x 27cm (23.5" x 18.75" x 10.25")	16kg (35.2lbs)	881493004368	4

Technical drawings

Overall Dimensions

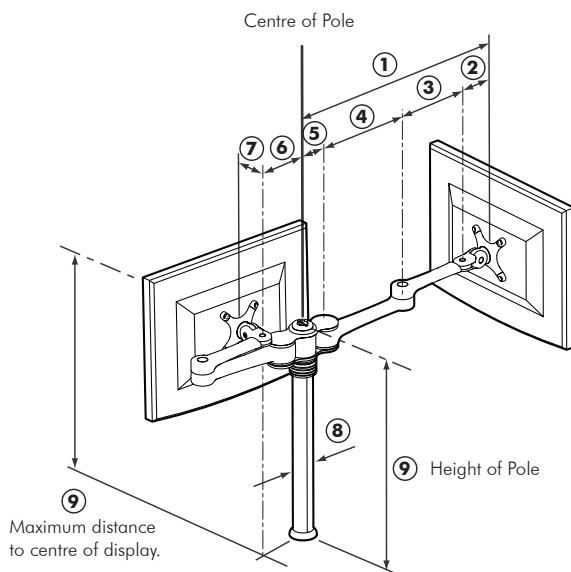

Note:

The back to back display configuration shown can only be used in conjunction with the **Bolt Through** mounting option.

The range of movement shown here applies to both arms of Focus Articulated Arm Double.

- ① Max. 467mm (18.39")
- ② 68mm (2.68")
- ③ 150mm (5.91")
- ④ 195mm (7.68")
- ⑤ 54mm (2.5")
- ⑥ 99mm (3.89")
- ⑦ Min. 68mm (2.68")
- ⑧ \varnothing 39mm (1.5")
- ⑨ 440mm (17.32")
or
450mm (17.71") when using Desk Clamp

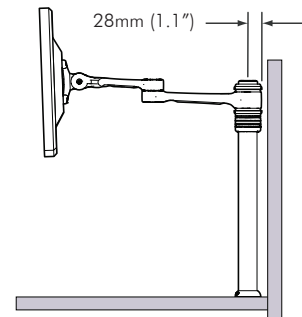

Desk Clamp

Desk clamp suits the following thicknesses of **0mm-99mm (0"-3.9")**

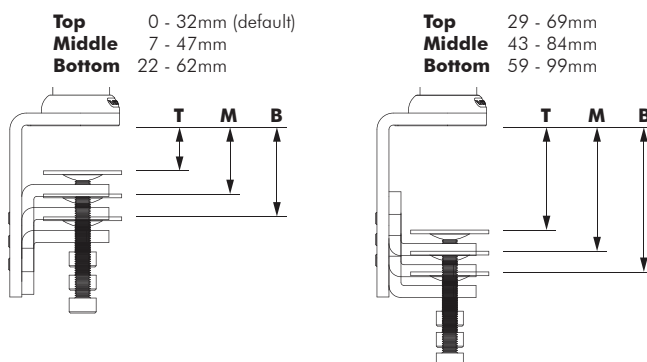

Bolt Through

Bolt Through suits desktop thicknesses of **12mm-40mm (0.5"-1.5")**

